



NJ-84A01

Full Extension Slides
150 pound class (68 kgs)



Loading

» Features » Drawing » Specification Table » Installation Instructions

Product Photo



Features



Mounting | Side mount.
Side Clearance | 12.7 mm pul 0.76 mm, minus 0 each side.
Height | 69.5 mm
Loading | 150 pound (68 kgs) class.
Size | 16", 18", 20", 22", 26"
Feature | Drop-close rail design for quick drawer installation.
Option | None.

Profile

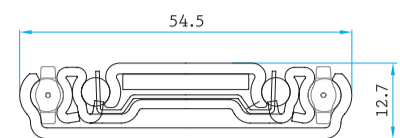

Surface Treatment

- Clear Zinc
- Black E. Coating
- Stainless Steel
- Black Zinc
- White E Coating
- Galvanized Steel

Packaging

- Distribution / 10 pairs per box
- Production

*Box QTY might vary with different length, the info provided here is based on 18" (450 mm)

Drawing

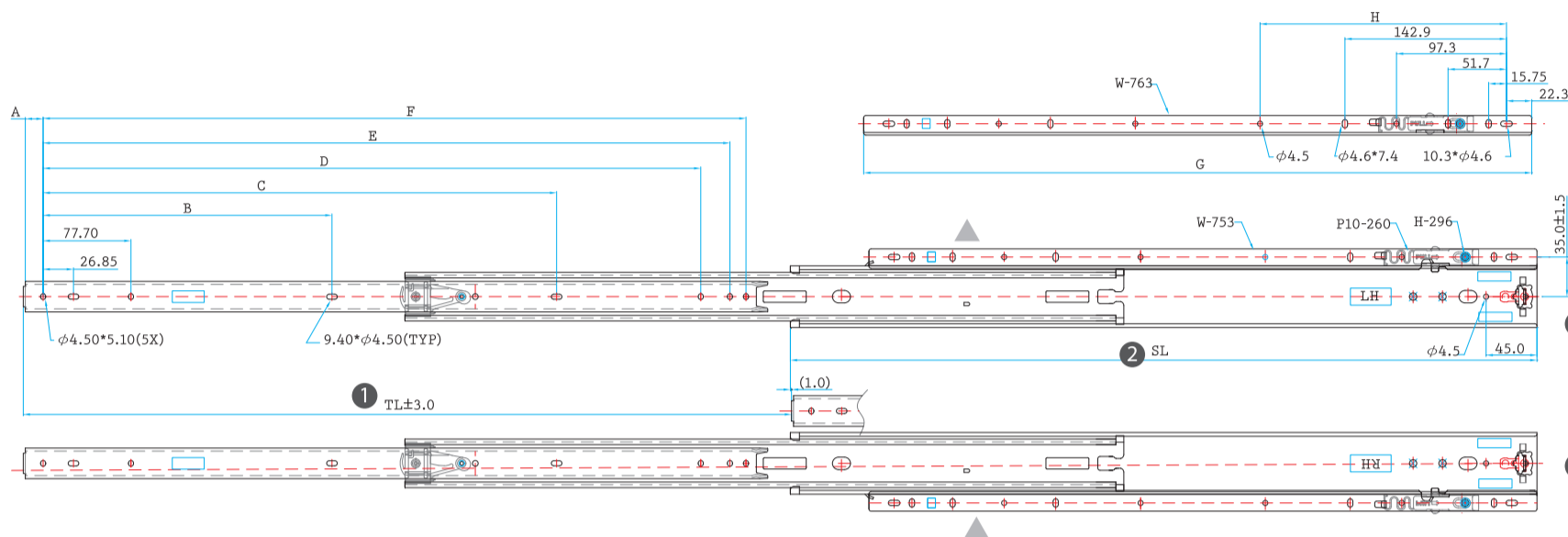

Profile

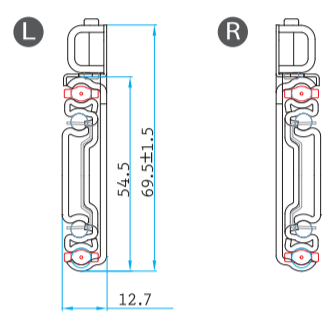

Specification Table

SIZE	SL	TL	A	B	C	D	E	F	G	H
16" (400mm)	403.1	439.0	17.35	245.25		322.20	347.90	362.20	380.50	
18" (450mm)	455.0	490.8	15.75	255.50		375.40	401.10	415.25	380.50	
20" (500mm)	508.0	527.2	15.75	255.50		405.40	431.10	445.30	492.50	209.30
22" (550mm)	555.7	574.8	15.75	308.50		477.00	502.80	517.00	492.50	209.30
26" (600mm)	660.4	679.5	15.75	255.50	454.20	581.70	607.50	621.70	590.90	218.00

Installation Instructions

QUICK INSTALLATION GUIDE OF NJ-84A01

Loading, Full Extension Slides, 150 pound (68 kgs) loading



READ THE QUICK INSTALLATION GUIDE FIRST BEFORE INSTALLATION

- A. One drawer requires 1 left hand slide, 1 right hand slide and 2 pieces of mounting rails (non-handed)
- B. Recommended screws for fixing - #8 pan head screws. Each side of slide requires at least 6 screws.

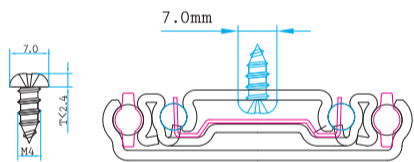

Technical Specifications for drawer or pull-out shelf

- ① Drawer or pulling-out shelf must be at least 12.8 mm narrower than cabinet opening on each side (DIM A)
 - ② Bottom of drawer or pulling-out shelf bottom shall have 6.4 mm or 1/4" minimum clearance from the bottom of Cabinet (DIM B)
 - ③ Mark a center line from the bottom of cabinet with the proper height (*H) (DIM C)
 - ④ Mark a center line from the bottom of drawer with the proper height (H-6.4 mm + 35 mm) (DIM D)
- * proper height (H) must not be shorter than 30 mm.

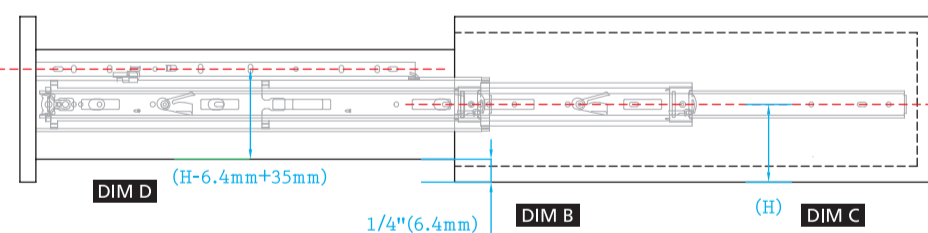

Step 1 > Install cabinet member to cabinet

- ➡ Pull the release latch forward to disconnect the mounting rail. (Figure1-1)

- ➡ Align the center line of cabinet member to the determined center line (H), and place slide 2 mm backward from cabinet opening. (Figure1-2)

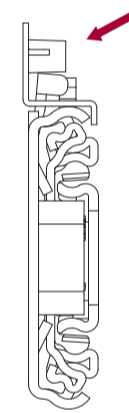

(Figure1)

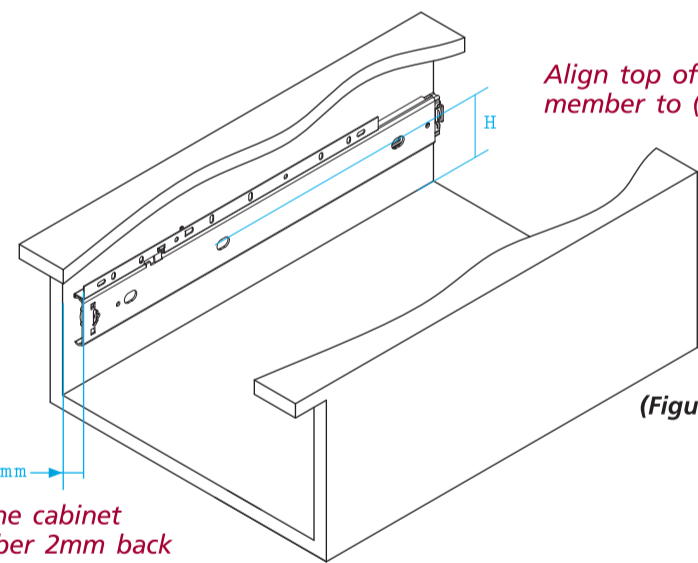

Align top of cabinet member to (H) line

Set the cabinet member 2mm back

(Figure1-2)

- ➡ Fix the slides through slots. Leave the screw loose for final adjustment. Move the slide back and forth, and make sure no screw is bound.

Step 2 > Install drawer member to drawer

- ➡ Align the center line of mounting rail to the determined center line (H-6.4 mm + 35 mm), and place the rail 2 mm backward from the drawer front or the pulling-out shelf edge. Shall the silencing cushion is used, place drawer member 5.2 mm backward. (Figure2-1)
- ➡ Fix the drawer member through slots on mounting rail. Leave the screw loose for final adjustment.

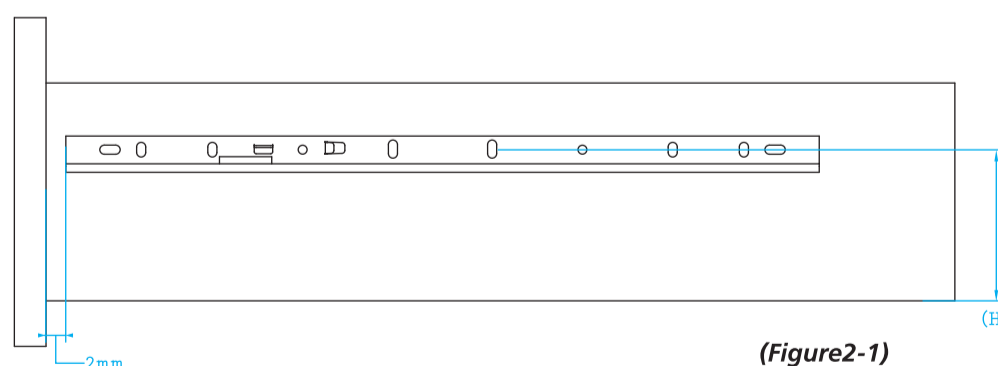

(Figure2-1)

Step 3 > Mount drawer on the slides

- ➡ Place the mounting rail on the slides, and make sure the rail go under the hook. Then, drop the drawer, and the mounting rail shall automatically engage with the pre-formed hook on the cabinet member. (Figure3-1)
- ➡ Try to lift the drawer up to see if mounting rails are well-engaged with the hook.

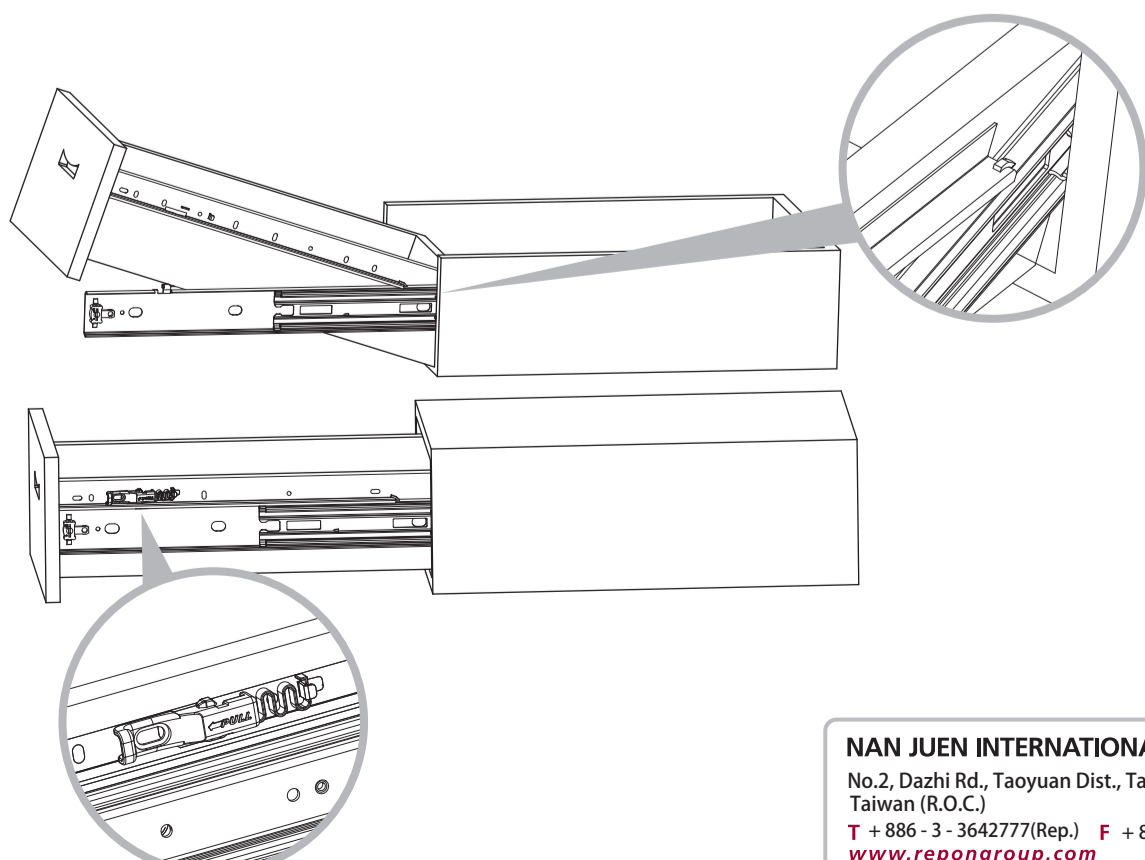

Final Adjustment.....

Try to open and close the drawer to see if slides function correctly. If so, secure the screws and install additional screws as necessary.

*This instruction is for reference only. It may vary due to different applications.



NAN JUEN INTERNATIONAL CO., LTD.
No.2, Dazhi Rd., Taoyuan Dist., Taoyuan City 330, Taiwan (R.O.C.)
T + 886 - 3 - 3642777(Rep.) F + 886 - 3 - 3762777
www.repongroupp.com