



NJ-24007

Full Extension Slides
130 pound class (60 kgs)



LB Loading

» Features » Drawing » Specification Table » Installation Instructions

Product Photo



Features



Mounting | Side mount

Side Clearance | 12.7 mm plus 0.8 mm, minus 0 each side.

Height | 101.6 mm (4")

Loading | 130 pound (60 kgs) class.

Size | 300 mm through 700 mm at 50 mm increment

Feature | 32 mm hole pattern, attached release clip with quick disconnect rails for easy drawer removal. Progressive movement. Handed slide member.

Option | Mounting screws.

Profile

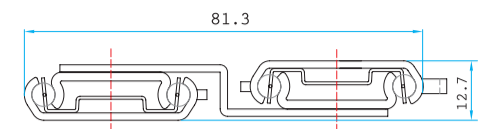

Surface Treatment

- Clear Zinc
- Black Zinc
- Black E. Coating
- White E Coating
- Stainless Steel
- Galvanized Steel

Packaging

- Distribution / 5 pairs per box
- Production

*Box QTY might vary with different length, the info provided here is based on 18" (450 mm)

Drawing

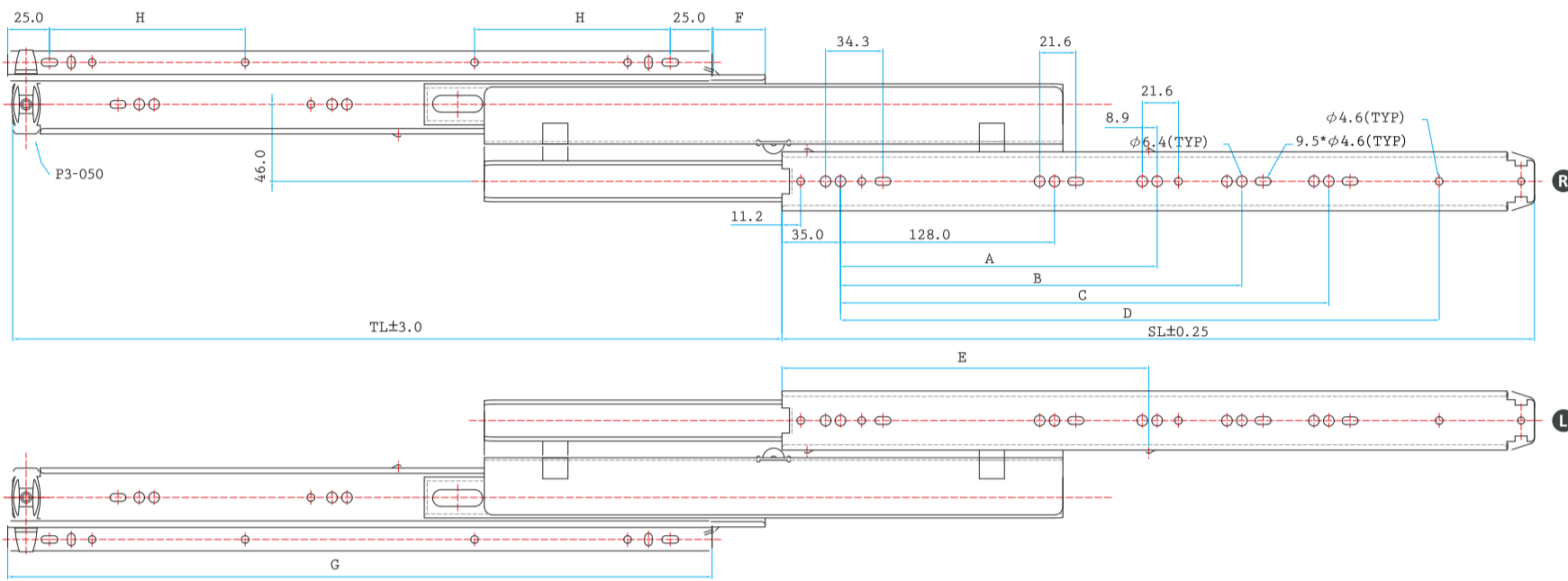

Profile

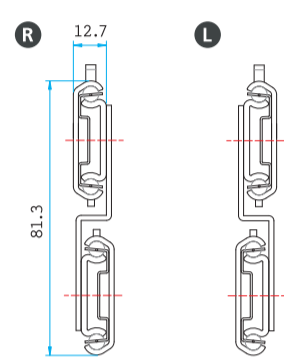

Specification Table

SIZE	SL	TL	A	B	C	D	E	F	G	H
12" (300mm)	300.0	312.4	224.0				143.1	31.4	268.8	
14" (350mm)	350.0	361.6	224.0				168.5	31.4	319.6	117.0
16" (400mm)	400.0	410.8	224.0	320.0			193.9	31.4	370.4	117.0
18" (450mm)	450.0	460.0	224.0	352.0			219.3	31.4	421.2	117.0
20" (500mm)	500.0	509.2	224.0	416.0			244.7	31.4	472.0	117.0
22" (550mm)	550.0	558.4	224.0	352.0	448.0	480.0	270.1	28.4	522.8	117.0
24" (600mm)	600.0	620.3	224.0	352.0	480.0		295.5	28.4	573.6	117.0
26" (650mm)	650.0	669.5	224.0	352.0	544.0		320.9	28.4	624.4	117.0
28" (700mm)	700.0	718.7	224.0	352.0	544.0	608.0	346.3	58.4	645.0	117.0

Installation Instructions

QUICK INSTALLATION GUIDE OF NJ-24007

Loading, Full Extension Slides, 130 pound (60 kgs) loading



READ THE QUICK INSTALLATION GUIDE FIRST BEFORE INSTALLATION

- A. One drawer requires 1 left hand slide, 1 right hand slide and 2 pieces of mounting rails (non-handed)
- B. Recommended screws for fixing – #8 pan head screws for drawer fixing; #10 pan head for cabinet fixing. Each side of slide requires at least 6 screws (3 #8 for drawer, 3 #10 for cabinet)

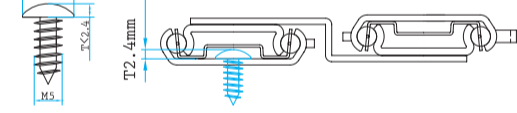

Technical Specifications for drawer or pull-out shelf

- ① Drawer or pulling-out shelf must be at least 13.00 mm narrower than cabinet opening on each side (DIM A)
 - ② Bottom of drawer or pulling-out shelf bottom shall have 6.4 mm or 1/4" minimum clearance from the bottom of Cabinet (DIM B)
 - ③ Mark a center line from the bottom of cabinet with the proper height (*H) (DIM C)
 - ④ Mark a center line from the bottom of drawer with the proper height (H-6.4 mm + 62 mm) (DIM D)
- * proper height (H) must not be shorter than 26 mm.

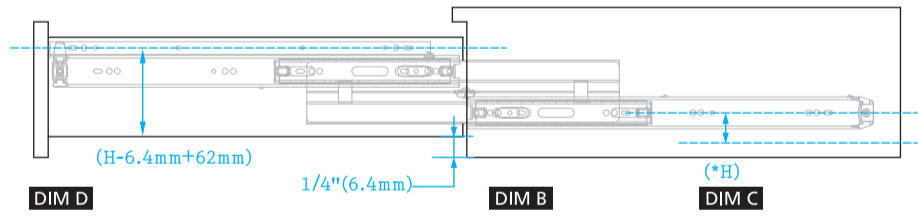

Step 1 > Install cabinet member to cabinet

- ➡ Press the release latch inward to disconnect the mounting rail. (Figure 1)

(Figure 1)

Disconnect the Rail

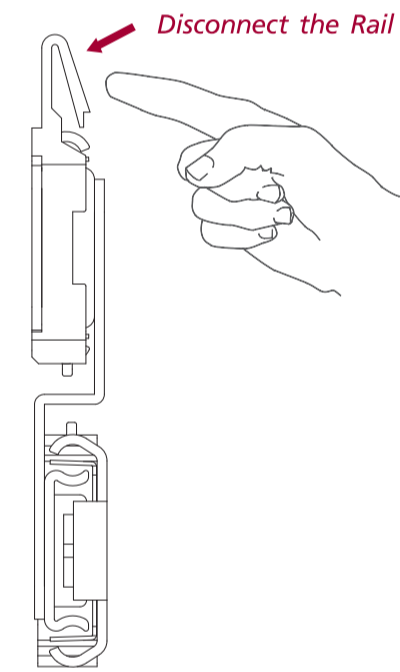

- ➡ Align the center line of the lower cabinet member to the determined center line (H), and place slide 2 mm backward from cabinet opening.

- ➡ Fix the slides through slots. Leave the screw loose for final adjustment. Move the slide back and forth, and make sure no screw is bound.

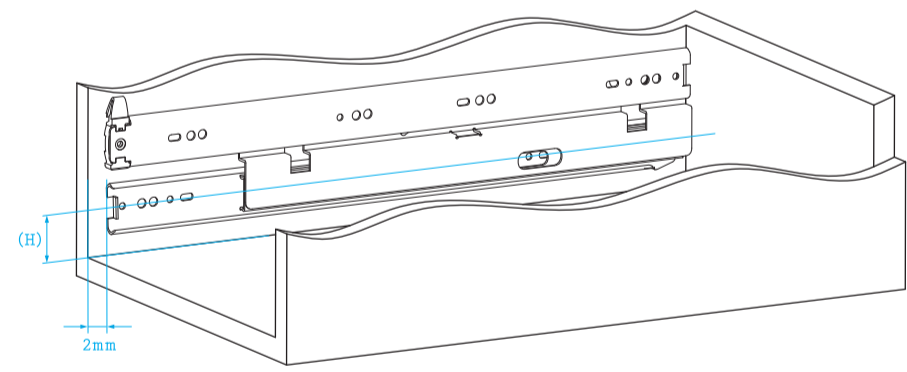

Step 2 > Install drawer member to drawer

- ➡ Align the center line of mounting rail to the determined center line(H-6.4 mm+62 mm), and place the rail 2 mm backward from the drawer front or the pulling-out shelf edge. Shall the silencing cushion is used, place drawer member 5.2 mm backward. (Figure 2)
- ➡ Fix the drawer member through slots on mounting rail. Leave the screw loose for final adjustment.

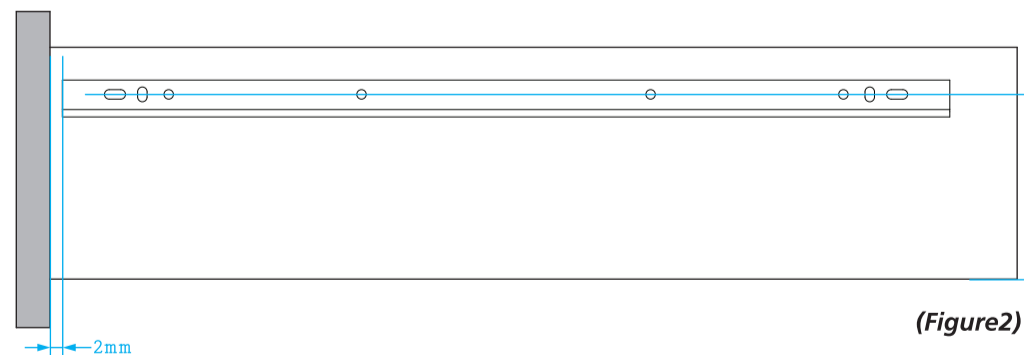

Step 3 > Mount drawer on the slides

- ➡ Place the mounting rail on the slides, and make sure the rail go under the hook, and the release latch go through square cutout on the opening end of mounting rail. (Figure 3)
- ➡ Try to lift the drawer up to see if mounting rails are well-engaged with the release latch.

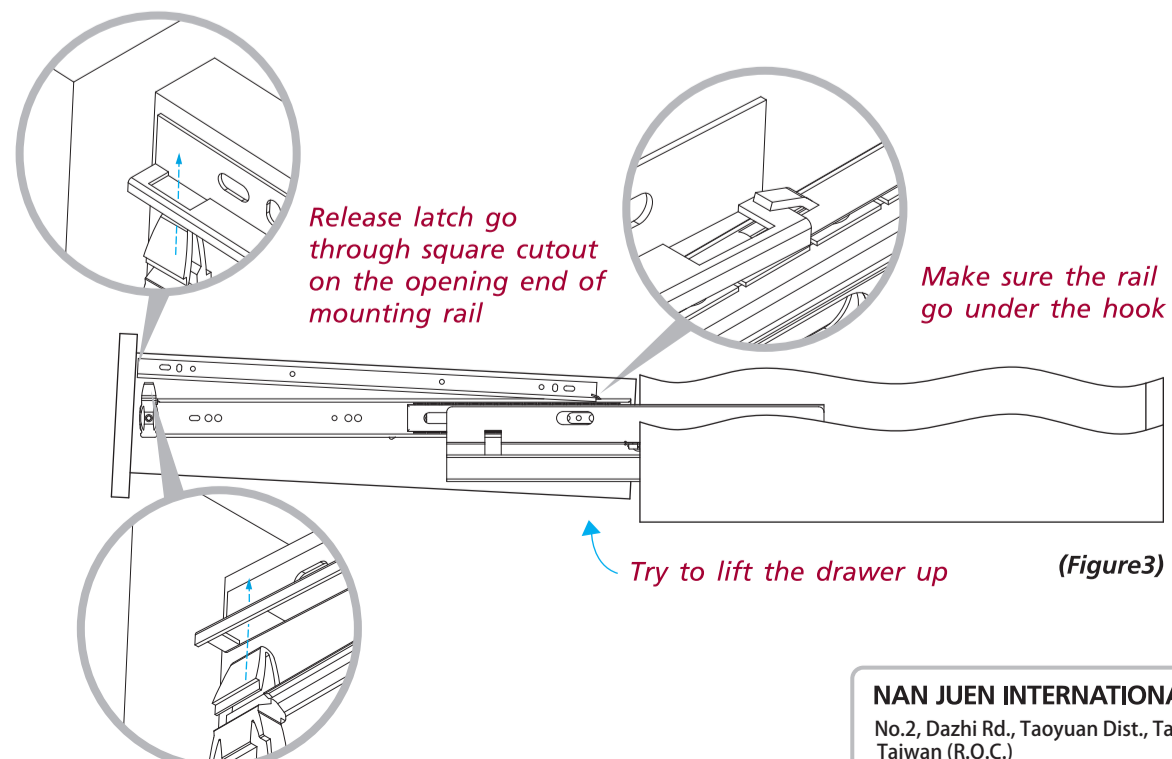

Final Adjustment.....

Try to open and close the drawer to see if slides function correctly. If so, secure the screws and install additional screws as necessary.

*This instruction is for reference only. It may vary due to different applications.



NAN JUEN INTERNATIONAL CO., LTD.
No.2, Dazhi Rd., Taoyuan Dist., Taoyuan City 330, Taiwan (R.O.C.)
T + 886 - 3 - 3642777(Rep.) F + 886 - 3 - 3762777
www.repongroupp.com