



NJ-23023

Under Counter Slides

50 pound class (22 kgs)



Under Counter

» Features » Drawing » Specification Table » Installation Instructions

Product Photo



Features



Mounting | Side mount of drawer members, bottom mount of cabinet members on underside of desk or table by mounting brackets.

Slide Clearance | 1-15/32" of NJ-2061, 1-1/16" of NJ-2062 each side.

Height | 3-1/32"

Loading | 50 pound (22 kgs) class.

Size | 12"(300 mm) through 24"(600 mm) at 2"(50 mm) increment.

Feature | Metal latch for positive out lock and easy removal. Safety protection bumper design. Outboard installation.

Option | Mounting screws. NJ-23026 : inboard installation.

Profile

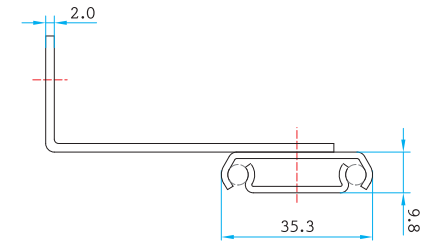

Surface Treatment

- Clear Zinc
- Black Zinc
- Black E. Coating
- White E Coating
- Stainless Steel
- Galvanized Steel

Packaging

- Distribution / 24 pairs per box

*Box QTY might vary with different length, the info provided here is based on 18" (450 mm)

Drawing

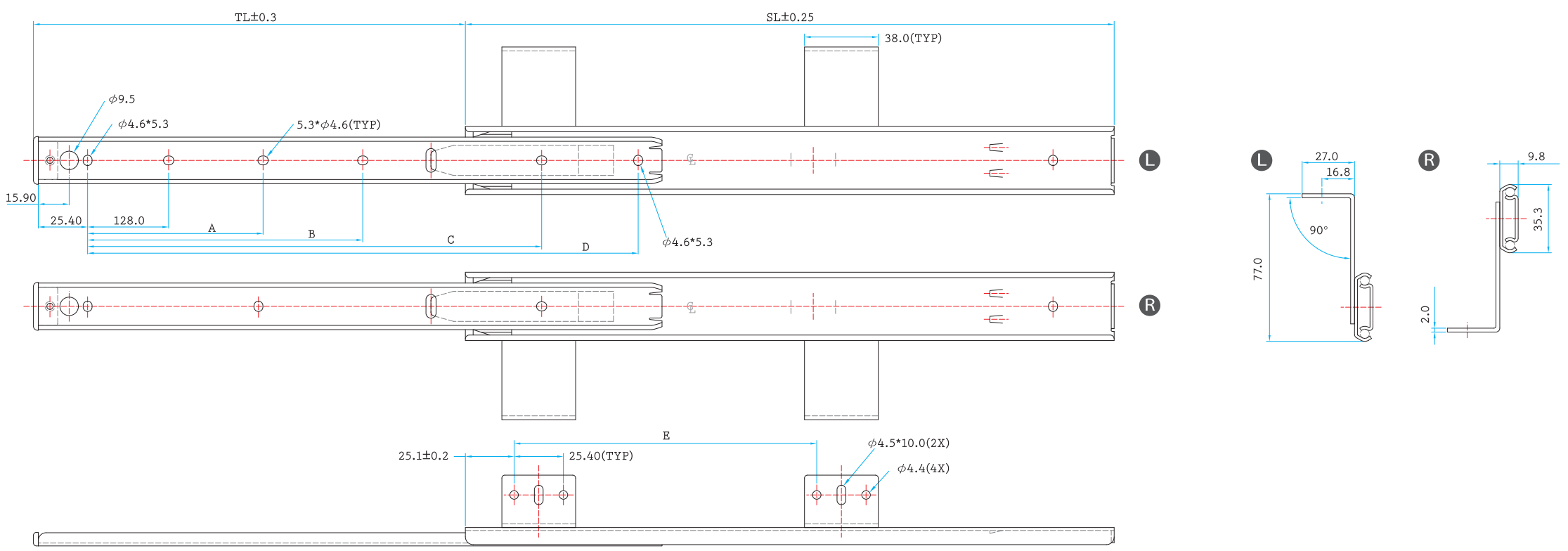

Specification Table

SIZE	SL	TL	A	B	C	D	E	S	T
12" (300mm)	302.05	199.0			212.3		215.9	302.05	199.0
14" (350mm)	352.85	249.5			263.1		215.9	352.85	249.5
16" (400mm)	403.65	300.0			313.9		215.9	403.65	300.0
18" (450mm)	454.45	330.5	256.0		343.6	401.3	215.9	454.45	330.5
20" (500mm)	505.25	381.0	256.0		394.4	452.1	215.9	505.25	381.0
22" (550mm)	556.05	406.0	256.0		419.8	502.9	419.1	556.05	406.0
24" (600mm)	606.85	431.5	256.0	352.0	445.2	553.7	419.1	606.85	431.5

Installation Instructions

QUICK INSTALLATION GUIDE OF NJ-23023

Under Counter Slides, 50 pound (22 kgs) loading



READ THE QUICK INSTALLATION GUIDE FIRST BEFORE INSTALLATION

A. Recommended screws for fixing – flat head 6 mm euro system screw or #8 pan head screws. Each side of slide requires at least 7 screws.

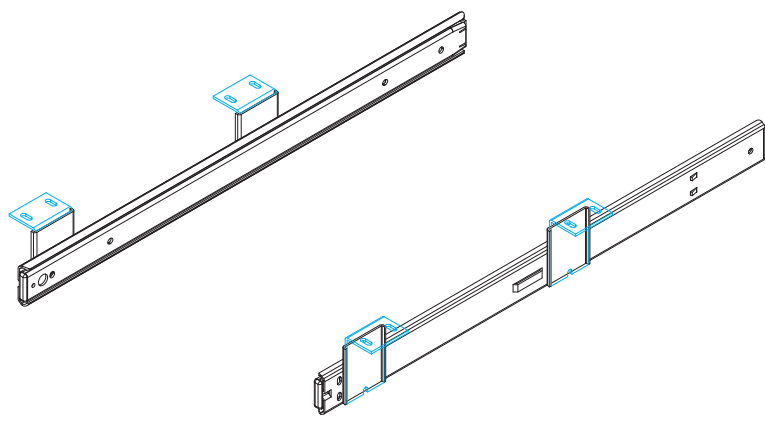

Step 1 > Install drawer member to the keyboard shelf

Press the release latch to disconnect the drawer member. (Figure1-1)

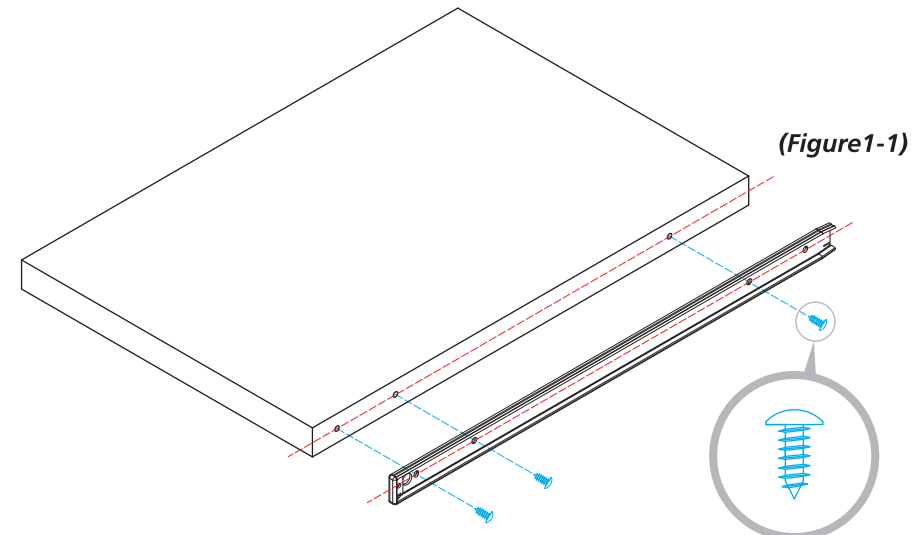

Align the center line of drawer member to the center line of keyboard shelf. (Figure1-2)

Affix the slide member with at least 3 #8 screws.

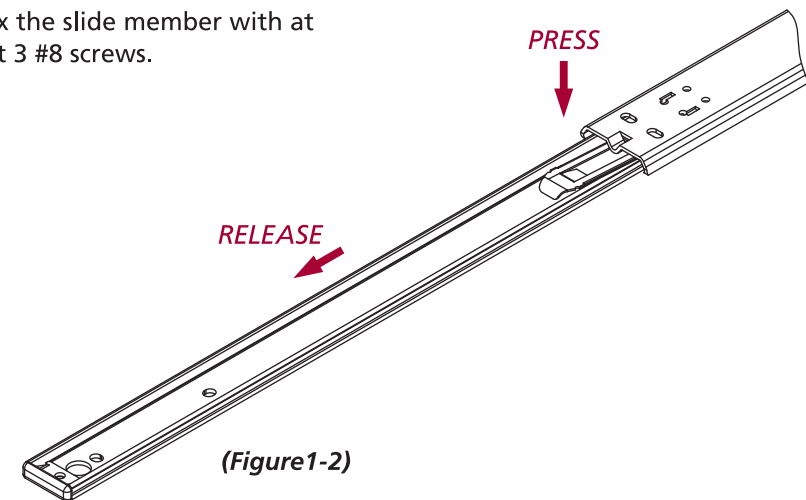

Step 2 > Install cabinet member to the desk bottom

Insert the drawer member mounted shelf into the slide cabinet member in order to determine the location of L shaped brackets. (Figure2-1)

Attach the brackets to the desk bottom and screw them with 2 #8 screws per bracket.

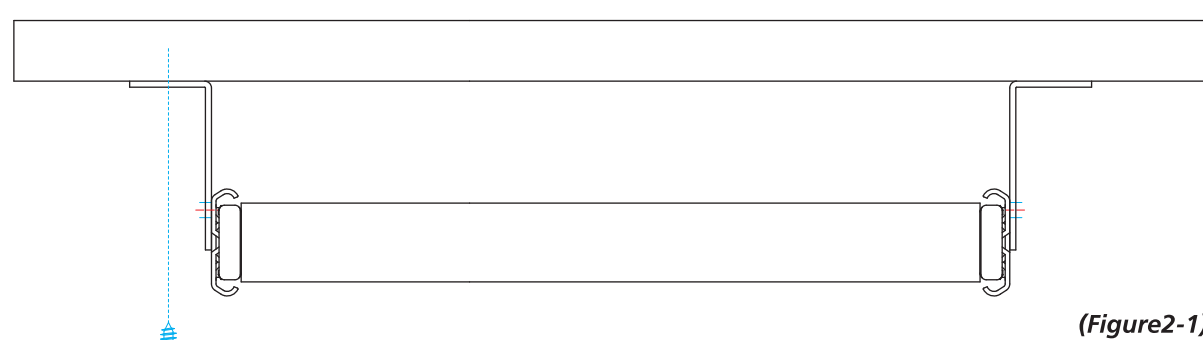

Final Adjustment.....

Try to open and close the drawer to see if lock open and slides function correctly. If so, secure the screws and install additional screws as necessary.

*This instruction is for reference only. It may vary due to different applications.

2#8 Pan head Screws per bracket

NAN JUEN INTERNATIONAL CO., LTD.
No.2, Dazhi Rd., Taoyuan Dist., Taoyuan City 330, Taiwan (R.O.C.)
T + 886 - 3 - 3642777(Rep.) F + 886 - 3 - 3762777
www.repongroupp.com

