

IMPORTANT

Before You Start



Linear Rail kit x 2



joining plate x 2



M8 Nut x 8

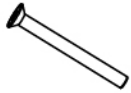

M8 x 80 Hex countersunk screw x 8



4.8mm phillip self-tapping screw x 12

Sliding countertop assembly

joining plate

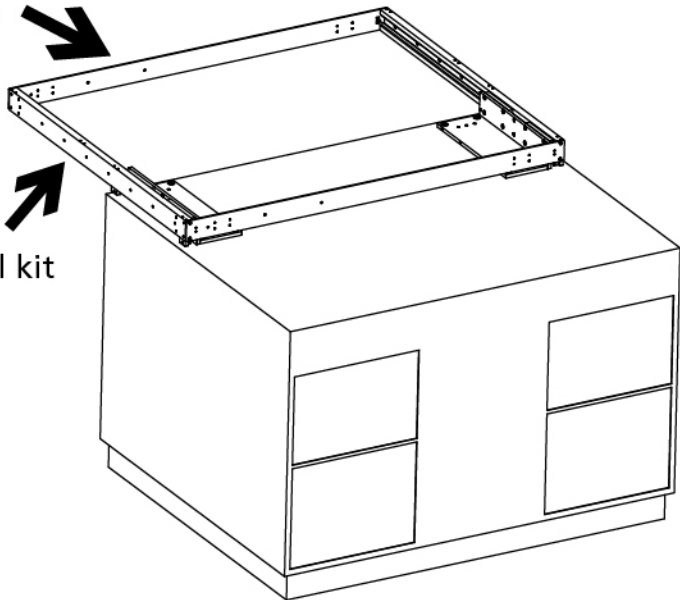

Linear Rail kit

Boring pattern of cabinet top

1200mm boring pattern

Hole diameter : 8.5mm to 9mm

Hole Qty: 8

Counter top cabinet body dimension

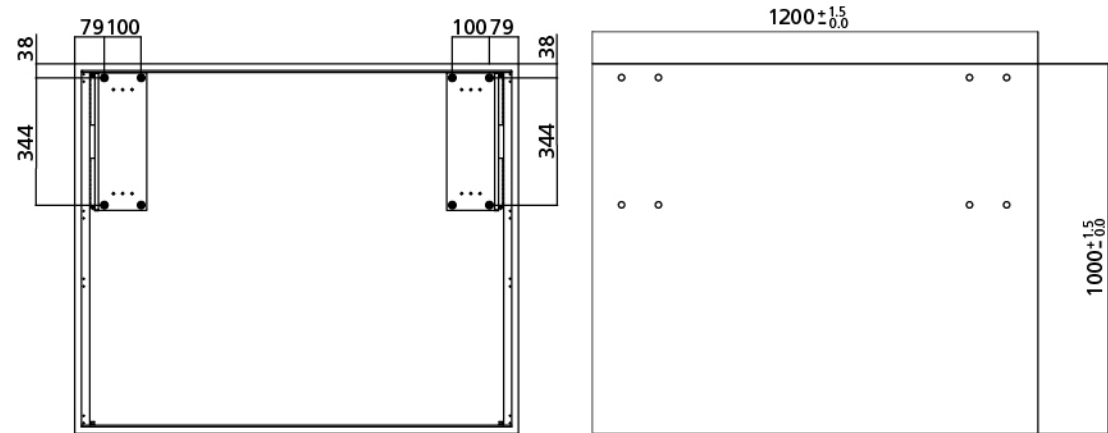

Installing linear rail kits and linkage bars

Using M5 x 35mm Hex round head screw

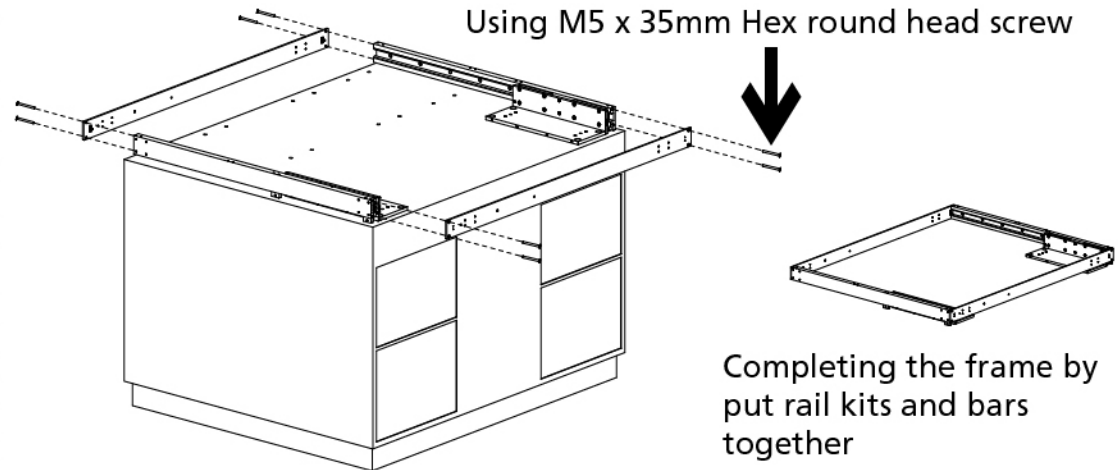

Completing the frame by put rail kits and bars together

■ Fix the countertop frame onto the island cabinet top

Using M8 x 80
Hex countersunk screws with M8 Nuts

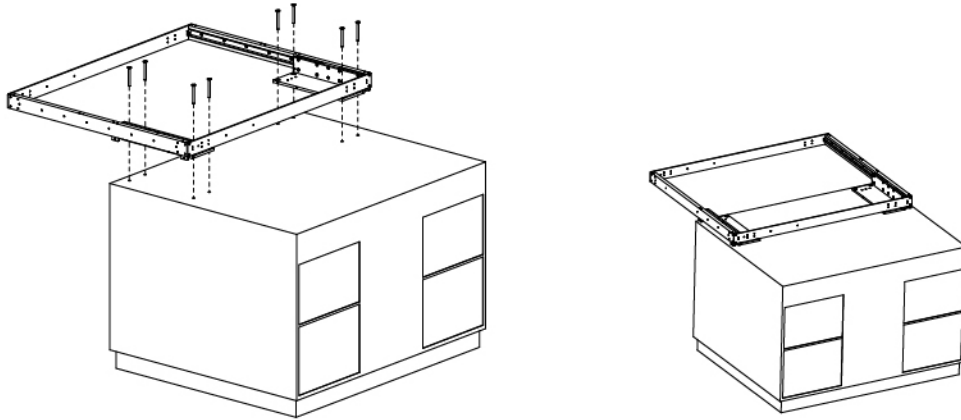

■ Prepare the countertop cover

1200mm countertop cover dimension
board dimension : 18mm
Countertop inner height : 72mm

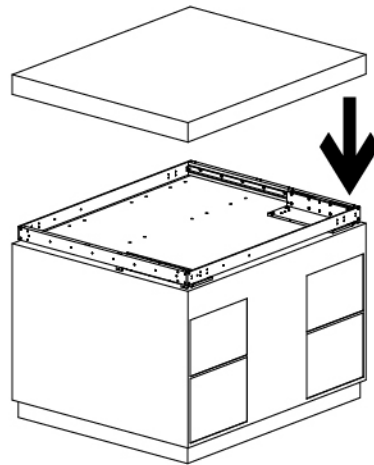
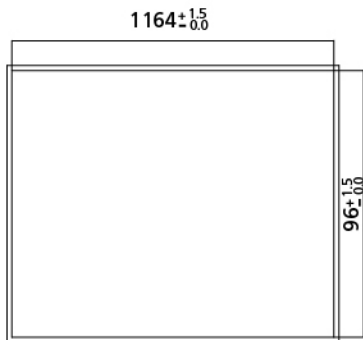

■ Boring pattern of cabinet top

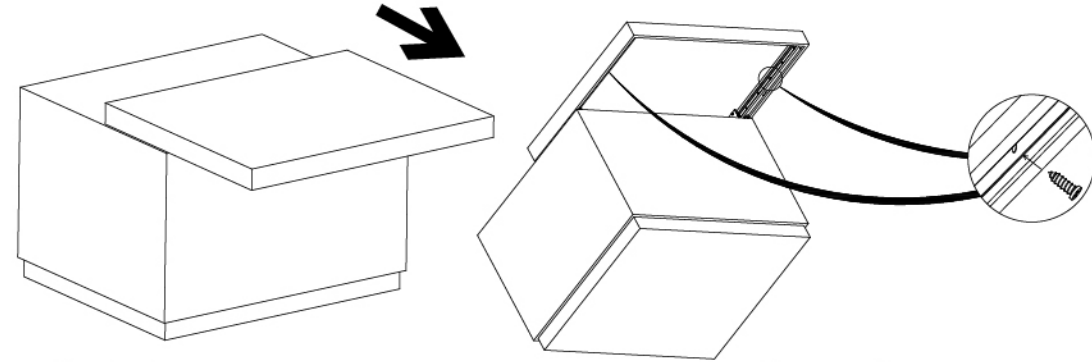

Push the countertop to
fully extended position

Secure the countertop
cover with 4.8mm self
tapping screws

■ Installation completed

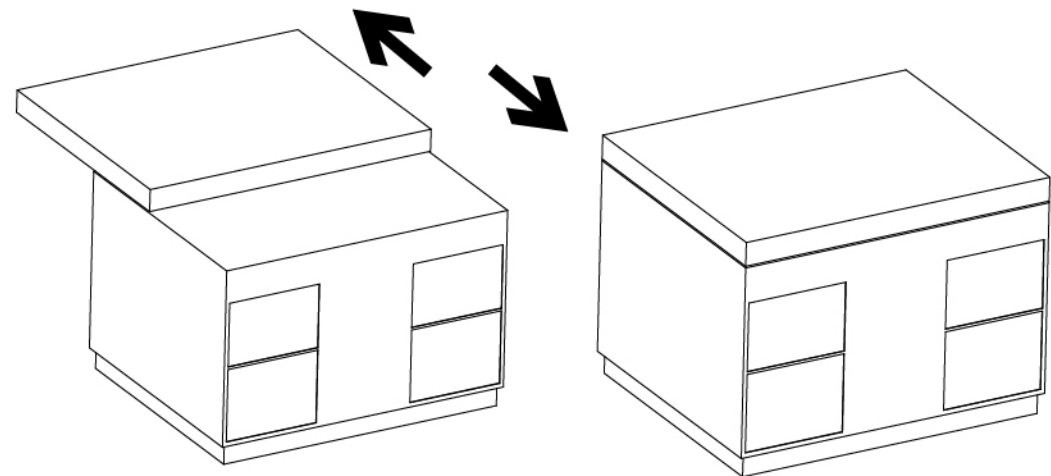

IMPORTANT

Before You Start

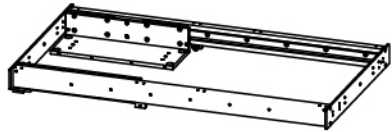

Linear Rail kit x 2



Linkage bar x 2



M8 Nut x 16



M8 x 80 Hex
countersunk screw x 16



M5 x 35mm
Hex round head
screw x 4



4.8mm phillip
self-tapping
screw x 10

Sliding countertop assembly

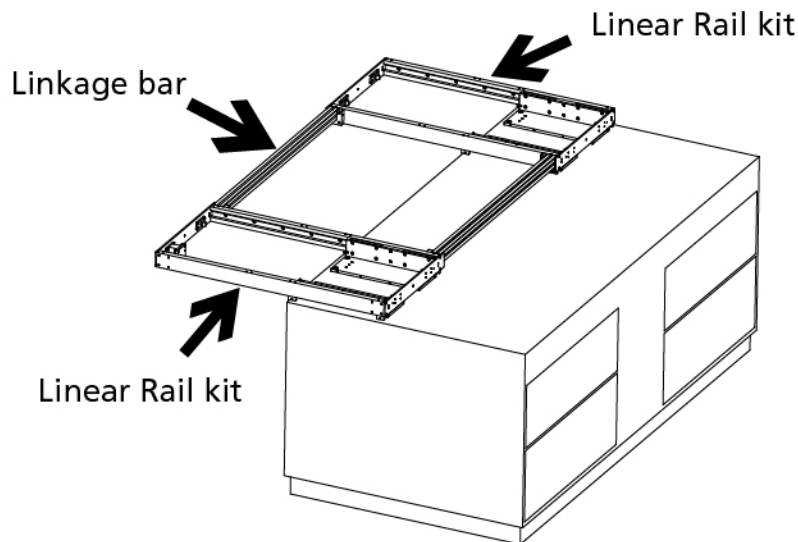

Boring pattern of cabinet top

1600mm boring pattern

Hole diameter : 8.5mm to 9mm

Hole Qty: 16

Counter top cabinet body dimension

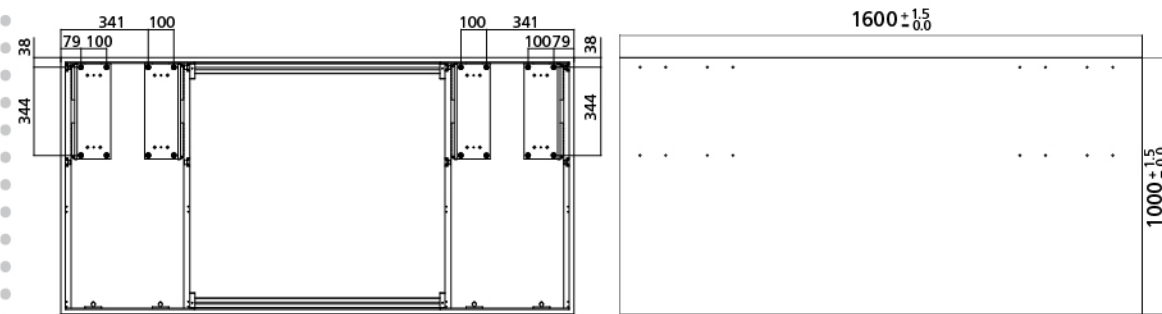

Installing linear rail kits and linkage bars

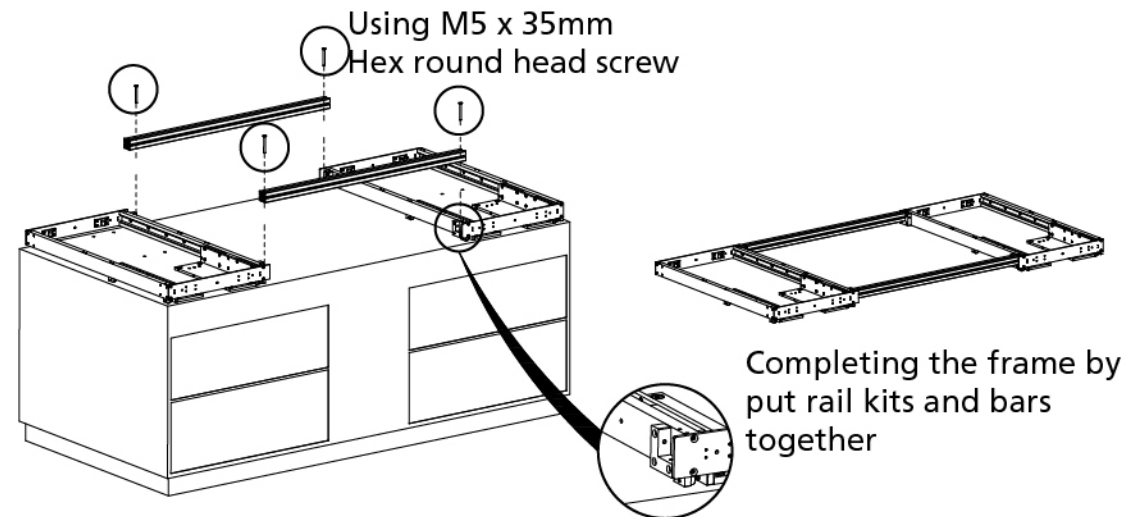

■ Fix the countertop frame onto the island cabinet top

Using M8 x 80
Hex countersunk screws with M8 Nuts

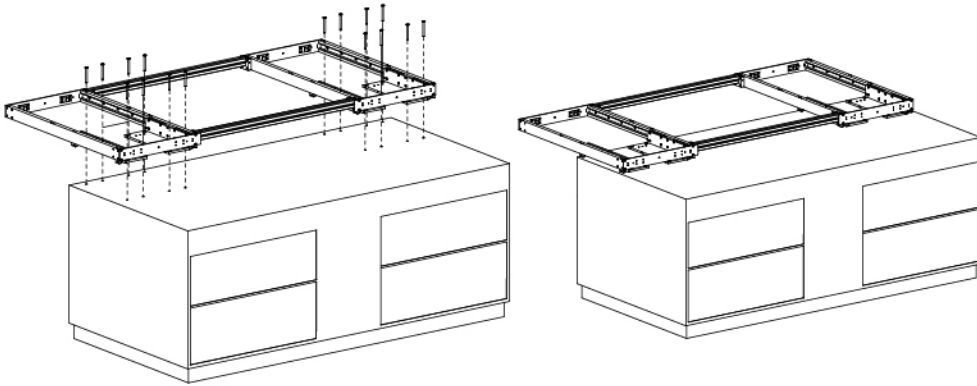

■ Prepare the countertop cover

1600mm countertop cover dimension
board dimension : 18mm
Countertop inner height : 72mm

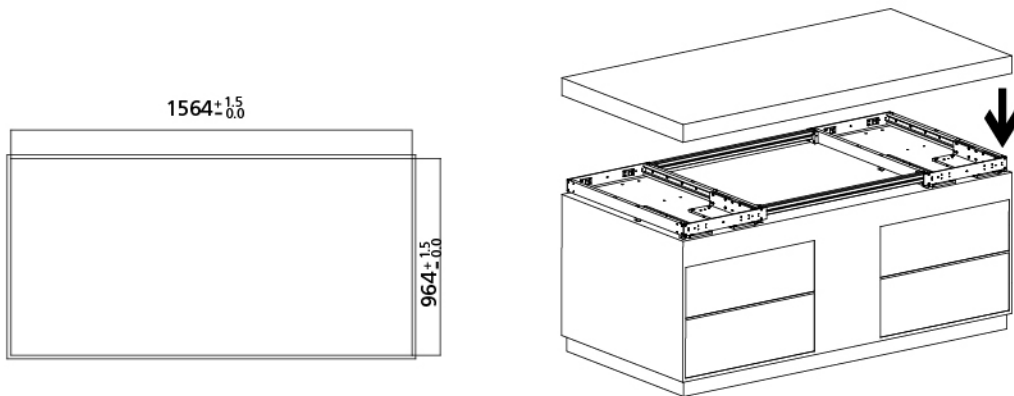

■ Boring pattern of cabinet top

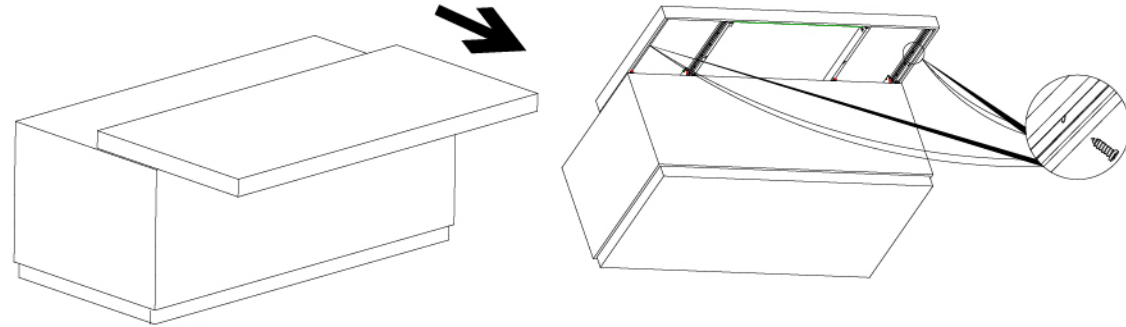

Push the countertop to
fully extended position

Secure the countertop
cover with 4.8mm
self tapping screws

■ Installation completed

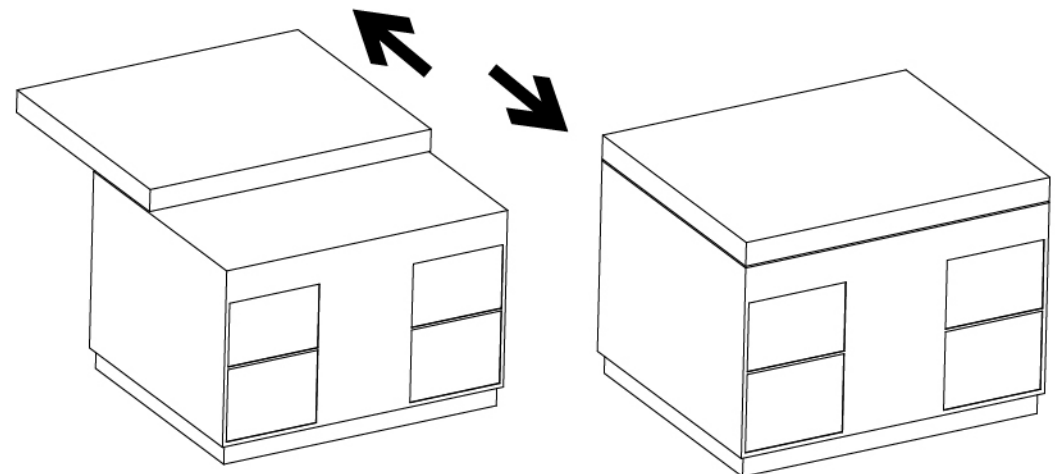

IMPORTANT

Before You Start

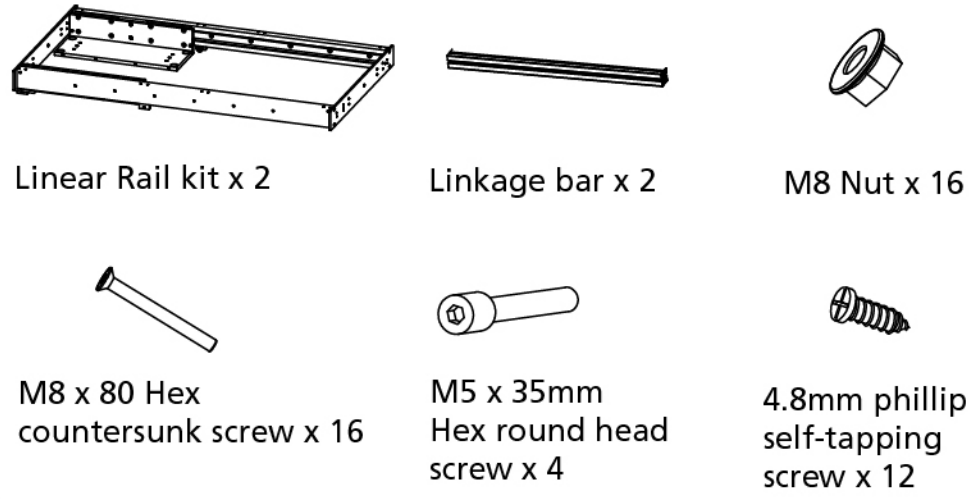

Boring pattern of cabinet top

2000mm boring pattern
Hole diameter : 8.5mm to 9mm Counter top cabinet body dimension
Hole Qty: 16

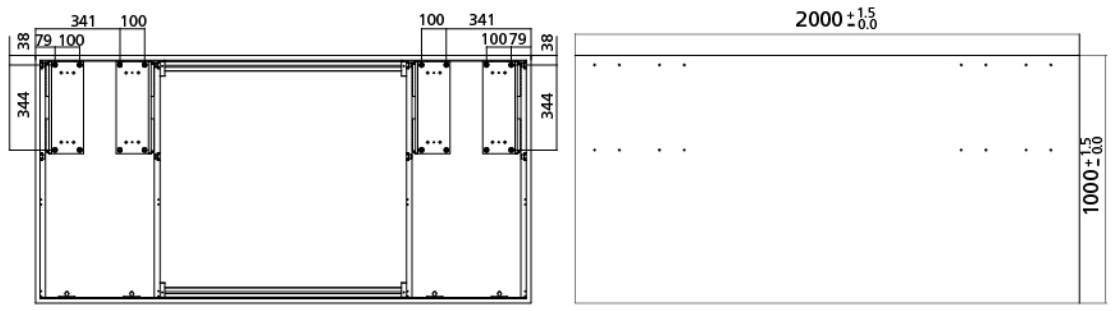

Sliding countertop assembly

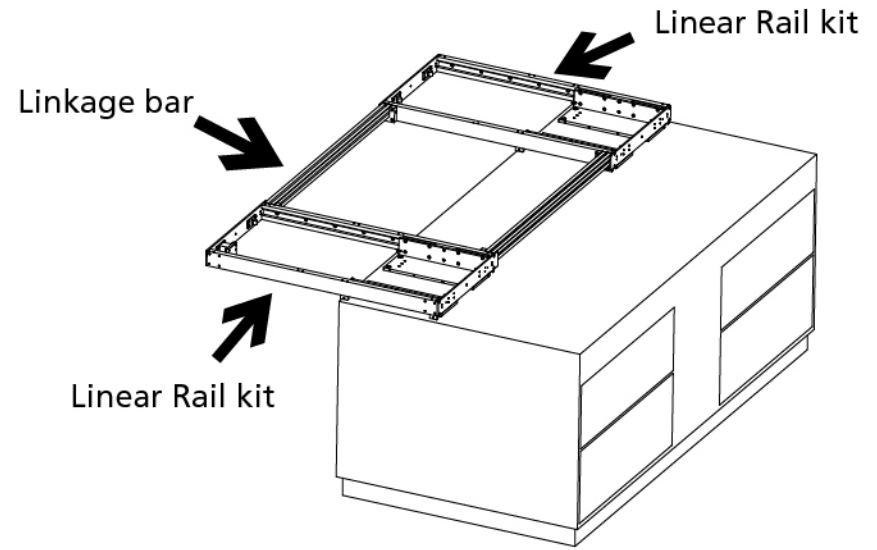

Installing linear rail kits and linkage bars

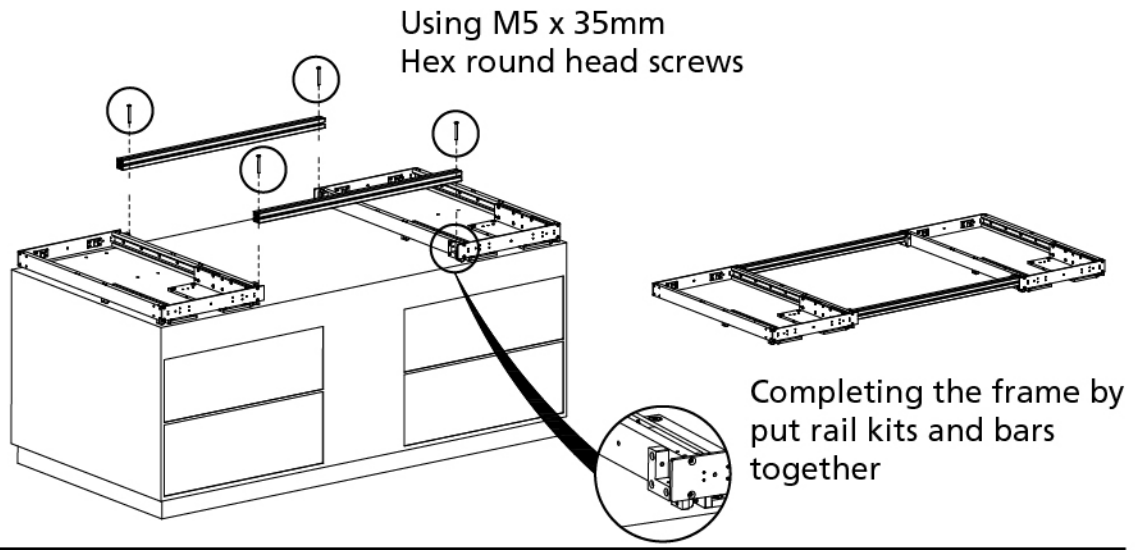

■ Fix the countertop frame onto the island cabinet top

Using M8 x 80
Hex countersunk screws with M8 Nuts

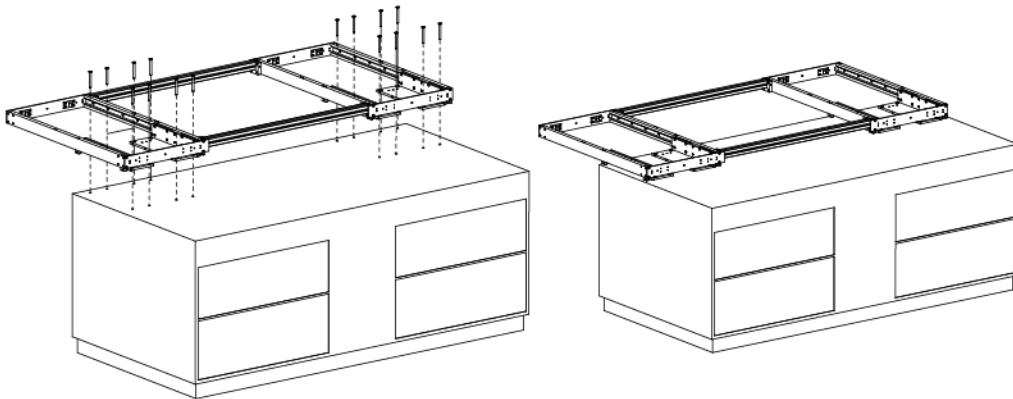

■ Prepare the countertop cover

1600mm countertop cover dimension
board dimension : 18mm
Countertop inner height : 72mm

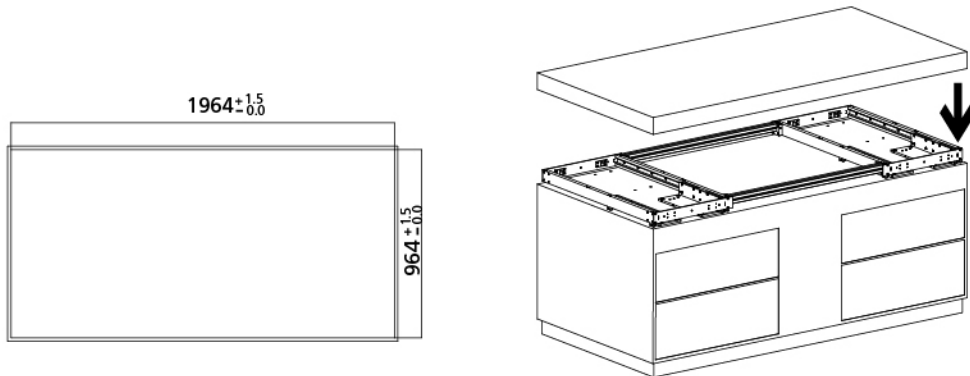

■ Boring pattern of cabinet top

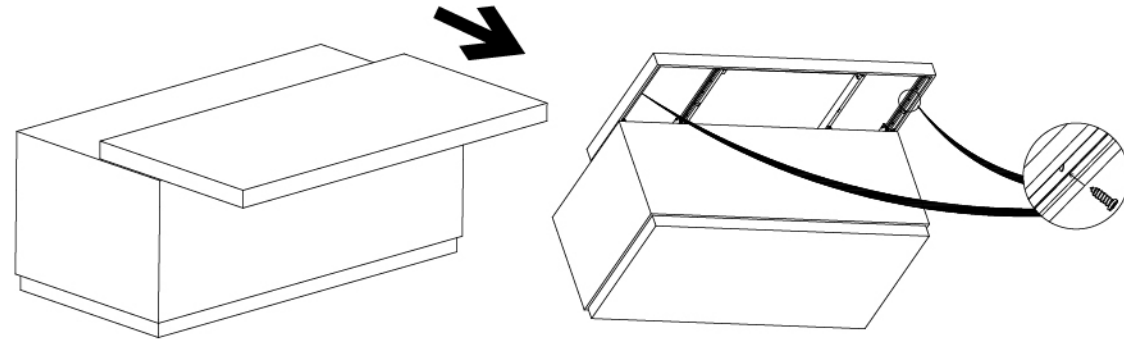

Push the countertop to
fully extended position

Secure the countertop
cover with 4.8mm
self tapping screws

■ Installation completed

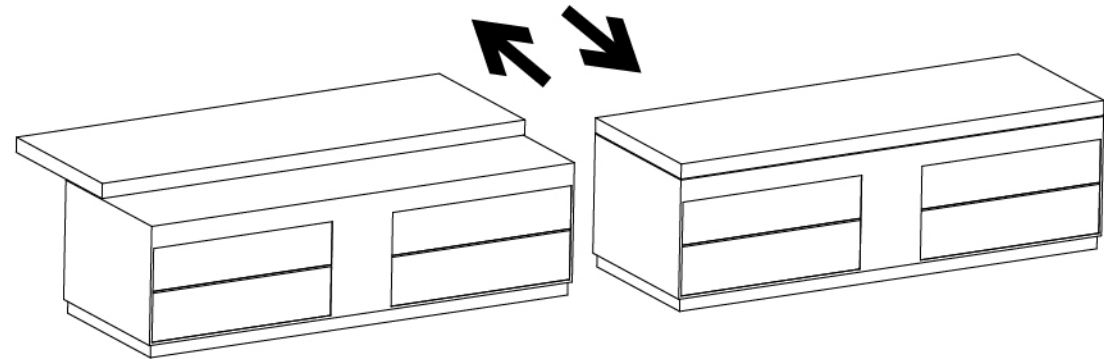

IMPORTANT

Before You Start

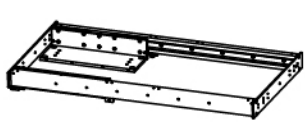

Linear Rail kit x 2

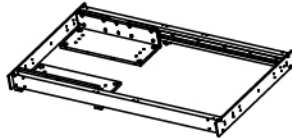

Linear Rail kit - M x 1



Linkage bar x 4



M8 Nut x 24



M8 x 80 Hex countersunk screw x 24



M5 x 35mm Hex round head screw x 8



4.8mm phillip self-tapping screw x 12

Boring pattern of cabinet top

2400mm boring pattern

Hole diameter : 8.5mm to 9mm Counter top cabinet body dimension

Hole Qty: 24

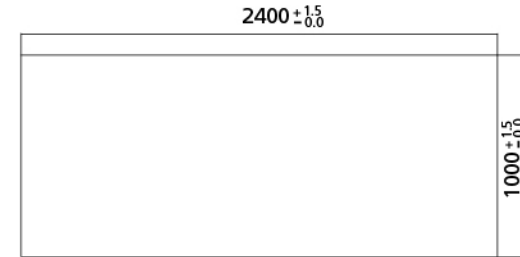
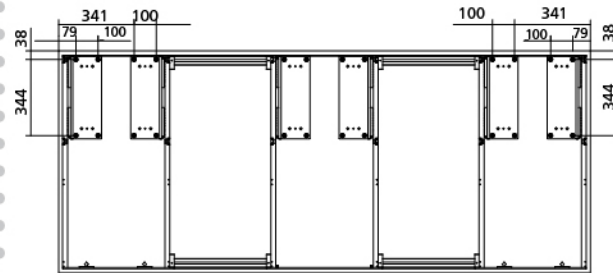

Sliding countertop assembly

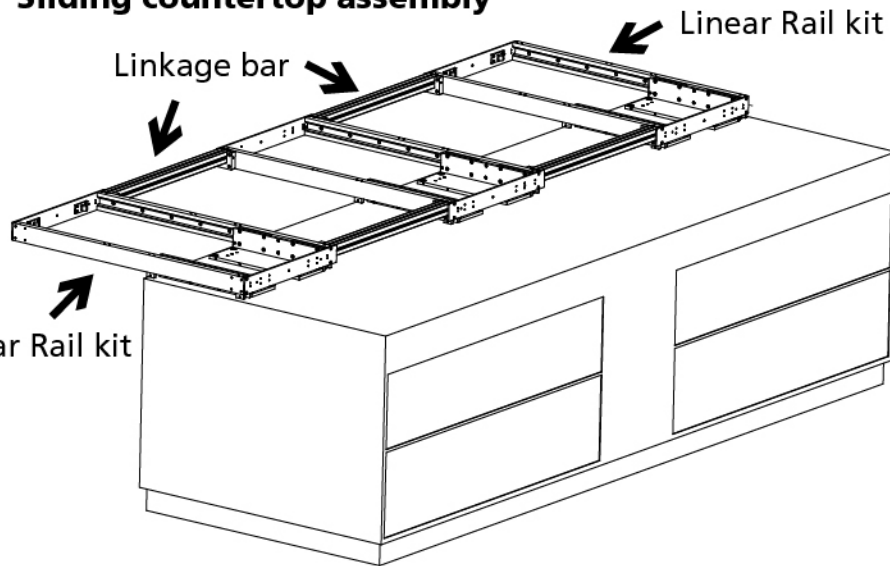

Installing linear rail kits and linkage bars

Using M5 x 35mm Hex round head screws

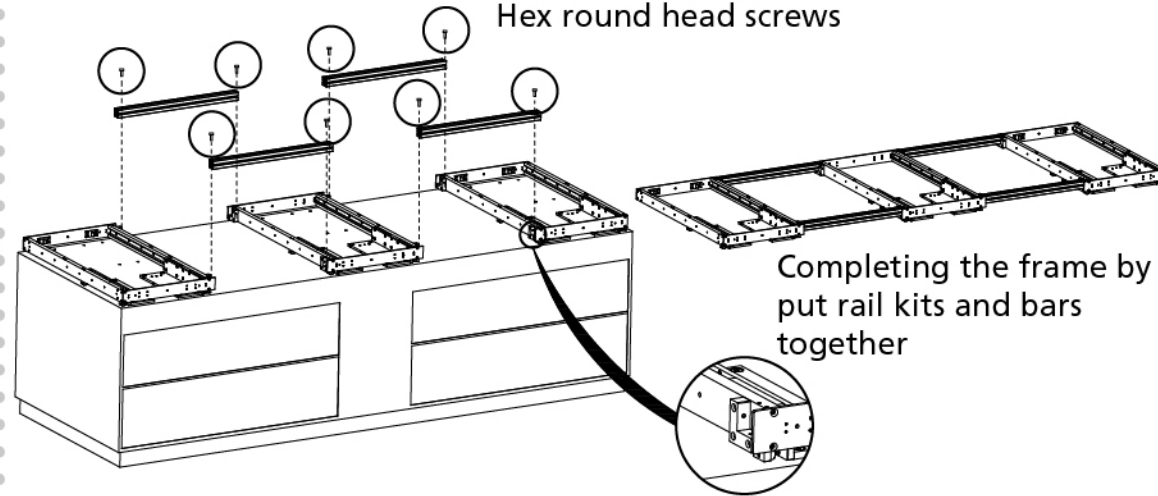

■ Fix the countertop frame onto the island cabinet top

Using M8 x 80
Hex countersunk screws with M8 Nuts

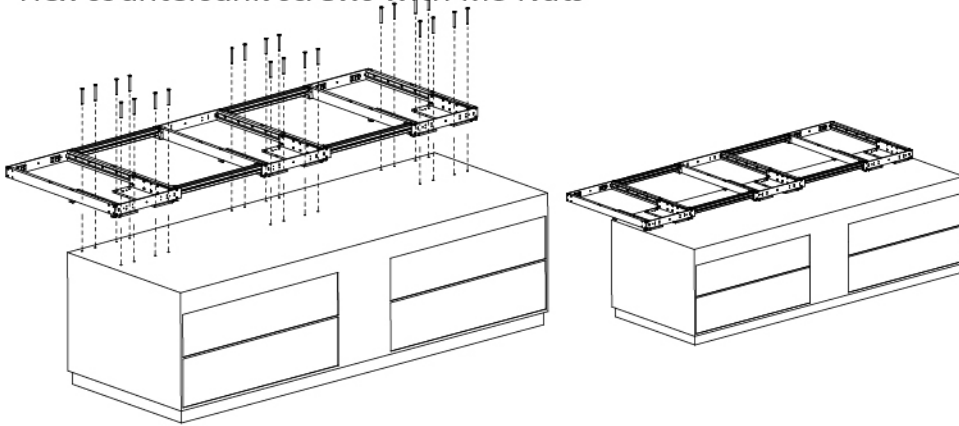

■ Prepare the countertop cover

2400mm countertop cover dimension
board dimension : 18mm
Countertop inner height : 72mm

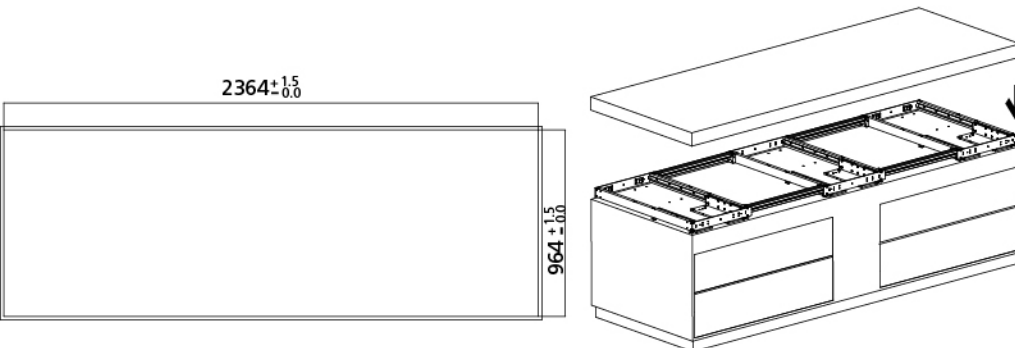

■ Boring pattern of cabinet top

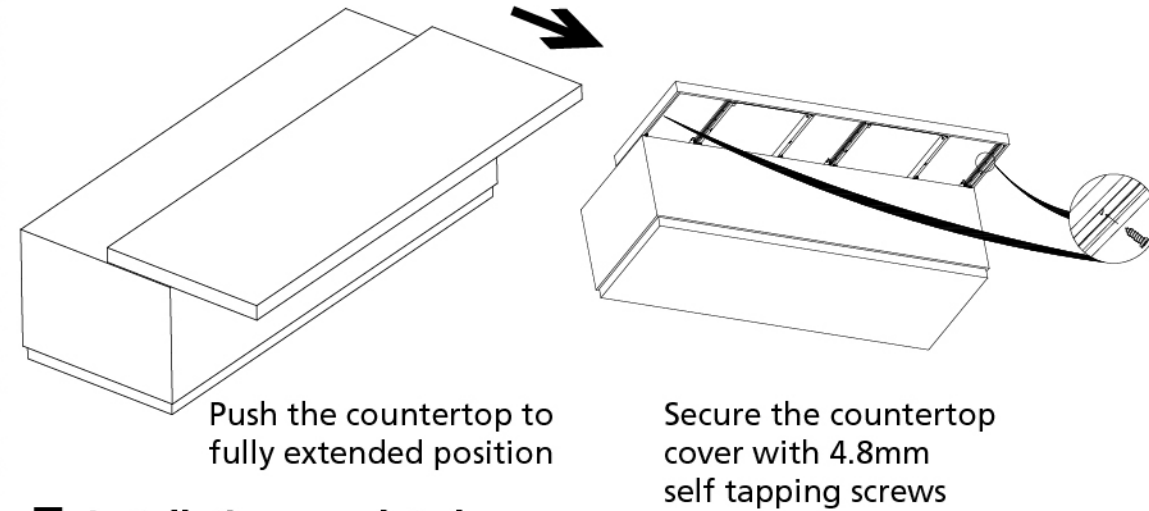

■ Installation completed

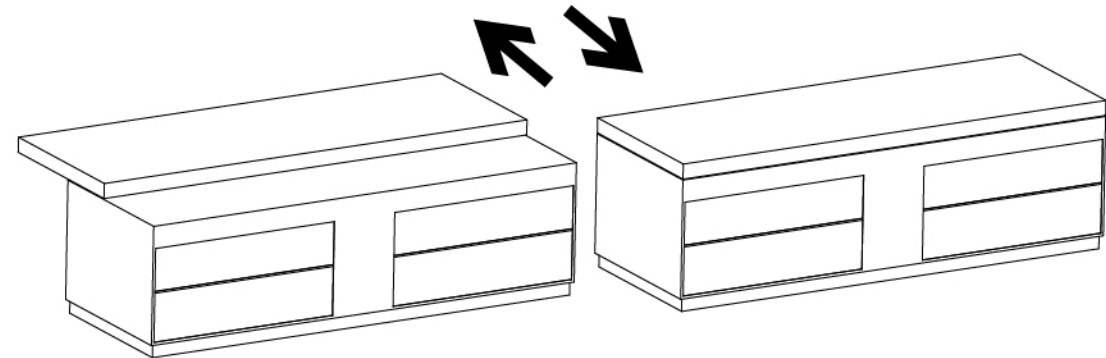

IMPORTANT

Before You Start

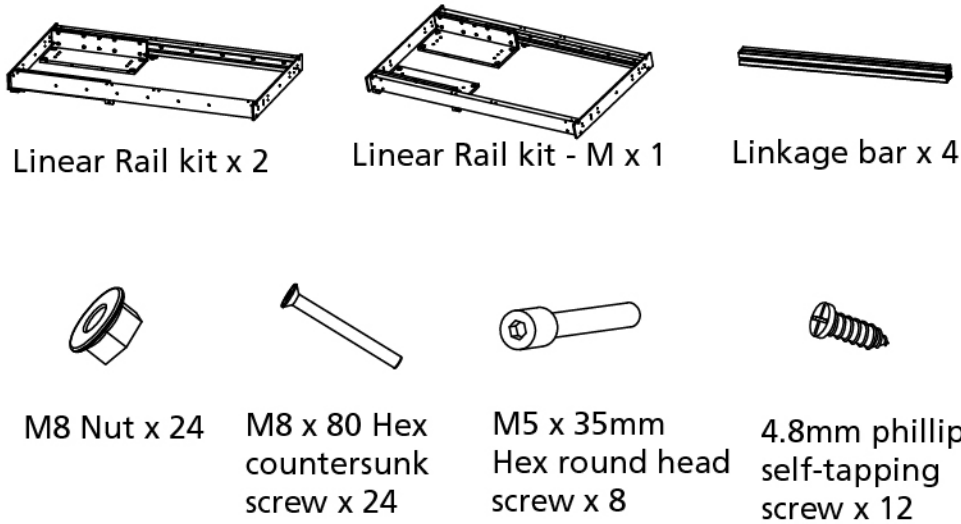

Sliding countertop assembly

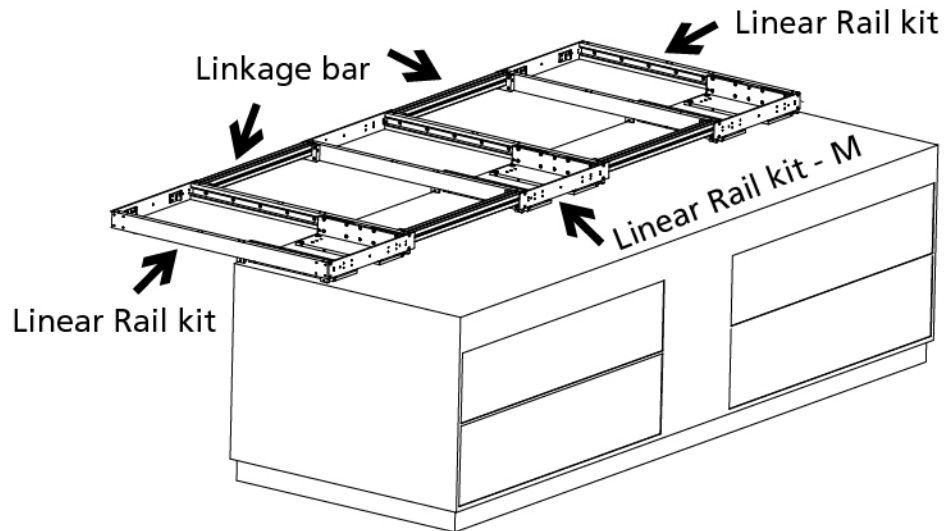

Boring pattern of cabinet top

2800mm boring pattern

Hole diameter : 8.5mm to 9mm

Hole Qty: 24

Counter top cabinet body dimension

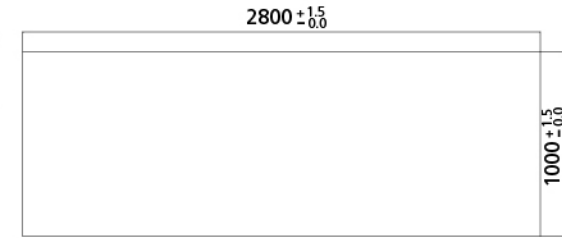
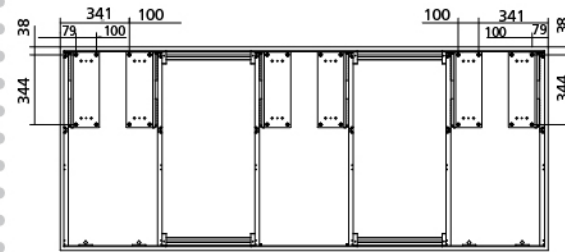

Installing linear rail kits and linkage bars

Using M5 x 35mm Hex round head screws

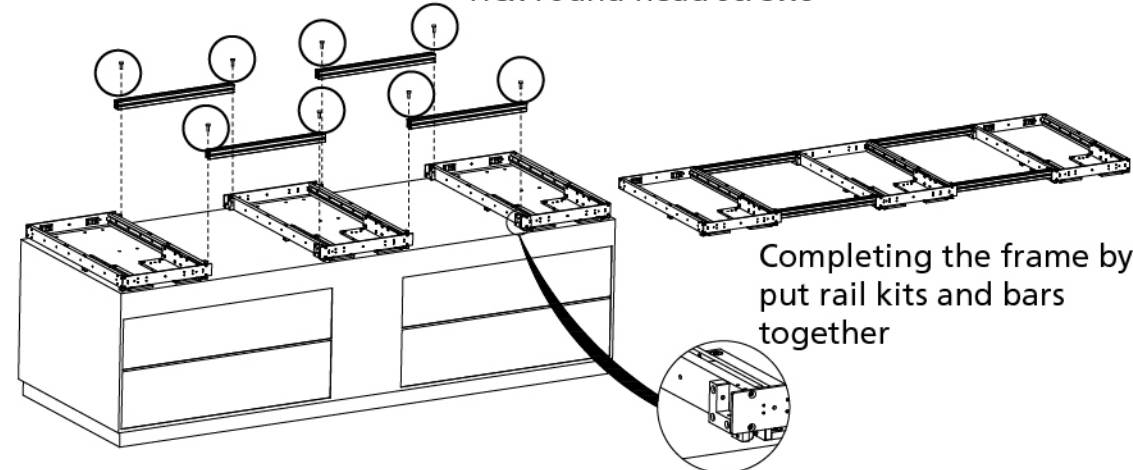

■ Fix the countertop frame onto the island cabinet top

Using M8 x 80
Hex countersunk screws with M8 Nuts

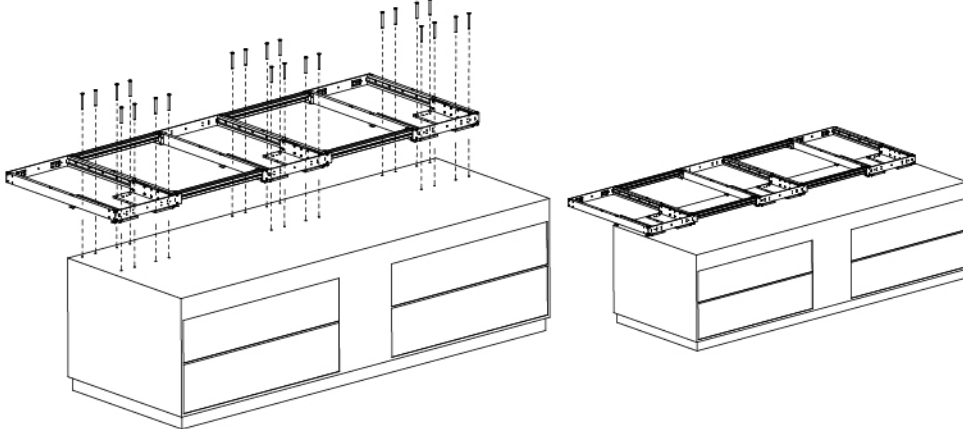

■ Prepare the countertop cover

2800mm countertop cover dimension
board dimension : 18mm
Countertop inner height : 72mm

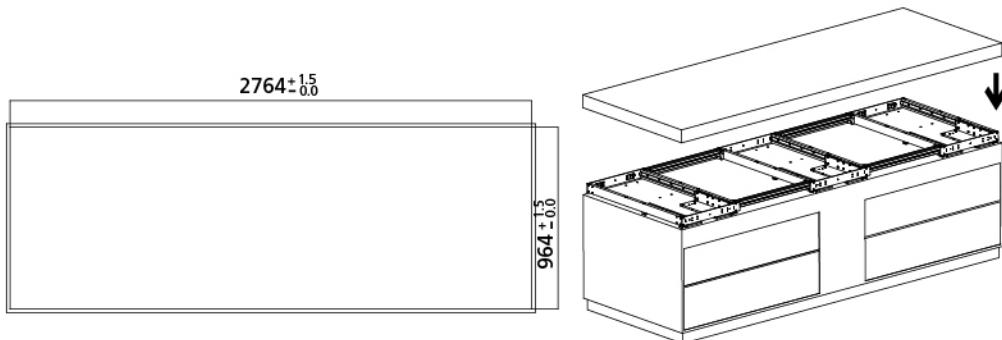

■ Boring pattern of cabinet top

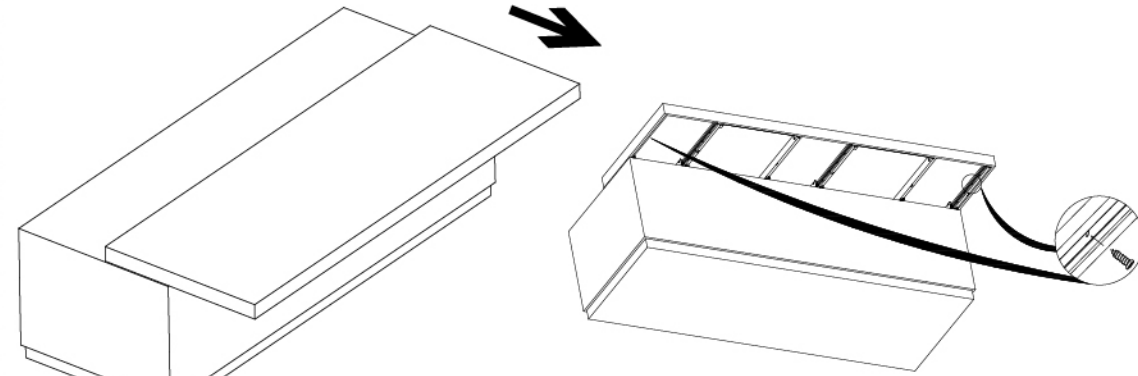

Push the countertop to
fully extended position

Secure the countertop
cover with 4.8mm
self tapping screws

■ Installation completed

